

SUBJECT: M20J RAM AIR REMOVAL - RETROFIT

MODEL/S/N
AFFECTED: M20J, S/N 24-0001 THRU 24-3153

TIME OF
COMPLIANCE: AT OWNERS DISCRETION

INTRODUCTION: The development of the M20J induction system and cowling created a near optimum design that has shown limited benefit from a ram air induction system. The components of the ram air are a source of maintenance over the life of the aircraft and therefore this retrofit is offered to those owners who may wish to remove the ram air system from the above serial numbered aircraft.

INSTRUCTIONS:

1. Remove upper and lower cowling (13) per M20J Service and Maintenance Manual, No. 121, Section 71-11-00. Refer to Figure SI 93-1 during the accomplishment of the following instructions.
2. Refer to Section 1 of Figure SI 93-1. Locate the air induction assembly (1); then locate the ram air housing assembly, (2) (P/N 600360-501). Remove ram air control cable assembly from lower butterfly arm of ram air housing assembly.
3. Remove rivets from flange of ram air housing and air induction assembly (1) (12 each rivets). The rubber seal (3) for contact/sealing between ram air housing and lower cowling will come off with the housing.
4. Refer to Section 2 of Figure SI 93-1. Remove ram air control cable assembly (4) from lower arm of the ram air housing assembly. Remove ram air control cable assembly (4) from attachment points (5), (6) and (7) along cable.
5. Remove the Ram Air Warning Light Switch components from the control cable assembly, see components at point (8).

CAUTION

Be certain to remove the Ram Air Switch components (8), not the Landing Gear Warning switch components attached to throttle cable assembly.

6. Tie electrical wire securely to an adjacent area where it will not interfere with normal control movement or powerplant control cable operation. Cap ends of both wire cables.
7. Ram Air Control Cable assembly is now ready to be pulled through the pass-through locations (9) of firewall (10) and console assembly (11). Undo attachment nuts from cable assembly on forward and aft side of console and at bulkhead fitting going through firewall. Carefully pull entire control cable assembly through the two holes.

CAUTION

The bulkhead/console fitting nuts will need to be worked off threaded portion of cable assembly as cable is withdrawn from engine compartment.

8. Remove RAM AIR decal from console face in cockpit.
9. Plug hole in bottom of air induction assembly, at point (5), with existing AN3-3A bolt and washer.
10. Plug holes in console (11) and firewall (10). Firewall hole should be plugged with bolt, nut and washers (large OD) included in kit. PRO SEAL 700 or equivalent sealant should be used to seal this firewall fitting. Console hole (11) can be plugged with any style plug, owners discretion. A Heyco 2633 plug is included in kit.
11. Refer to Section 3 of Figure SI 93-1. Install cover, (12) (P/N 600355-003) to Air Induction Assembly (1) with MS20470AD3 rivets. Seal this cover assembly, after installation on to air induction assembly, with RTV-White Silicone sealant (not included in kit). Be certain all possible air passages are thoroughly sealed.

12. Refer to Section 4 of Figure SI 93-1. The lower cowling Ram Air Inlet hole must be sealed over. AC43-13 approved standard practice procedures, fiberglass repair methods, should be used to accomplish this action. Complete this procedure and paint cowling.

WARRANTY: N/A

REFERENCE DATA: N/A

PARTS LIST: KIT PART NUMBER - SI M20-93-1-1

| ITEM | P/N | DESCRIPTION | QTY |
|------|--------------|--------------------|-----|
| 1. | 600355-003 | COVER | 1 |
| 2. | AN3-3A | BOLT | 1 |
| 3. | AN970-3 | WASHER, (LARGE OD) | 2 |
| 4. | MS21042-3 | NUT | 1 |
| 5. | MS20470AD3-4 | RIVET | 12 |
| 6. | No. 2633 | PLUG, HOLE (HEYCO) | 1 |

FIGURE/
TABLES: See Figure SI M20-93-1 below:

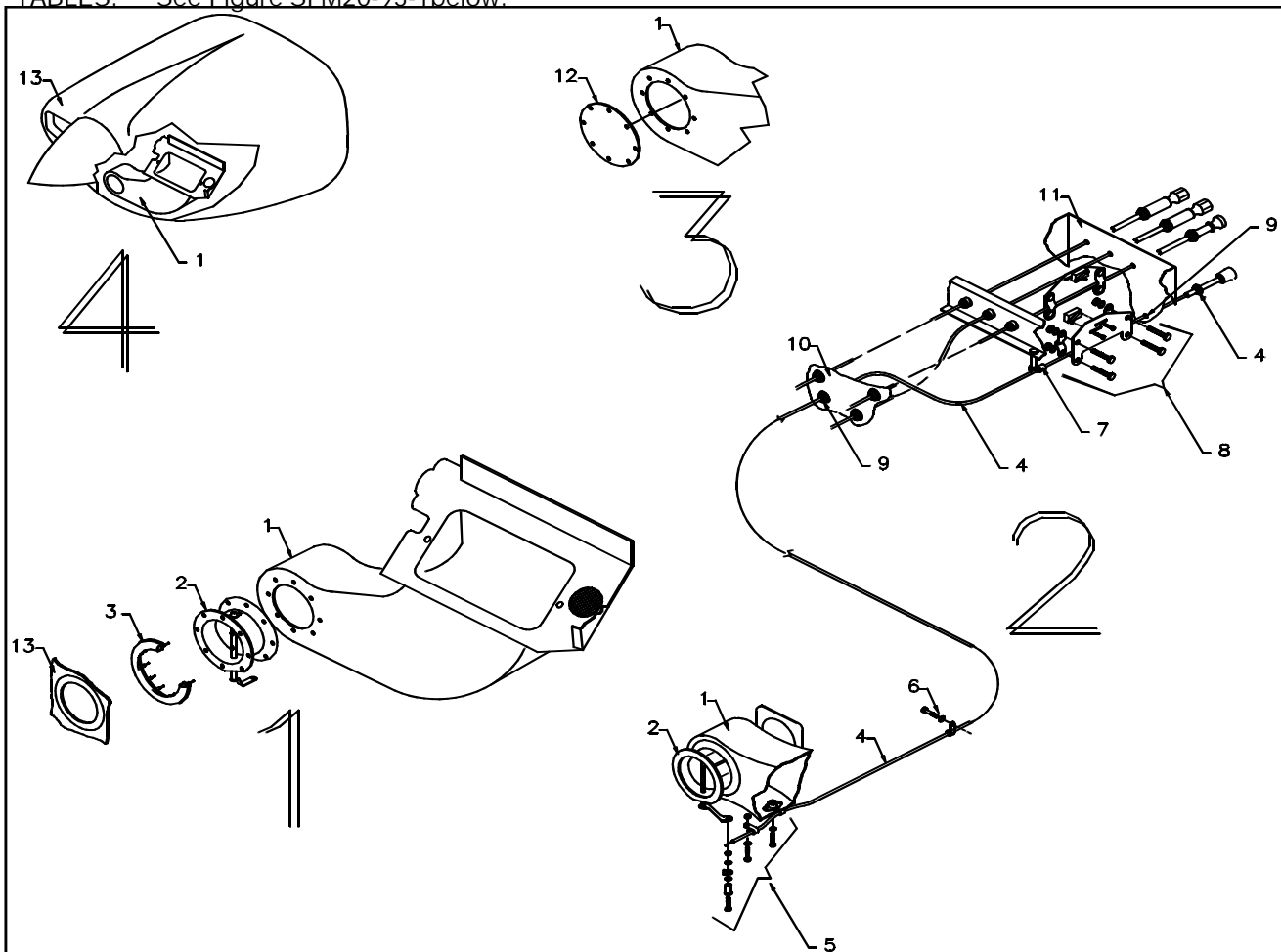

FIGURE SI-M20-93-1